



















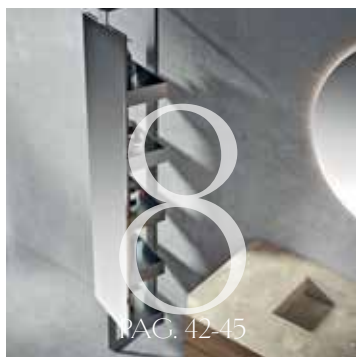
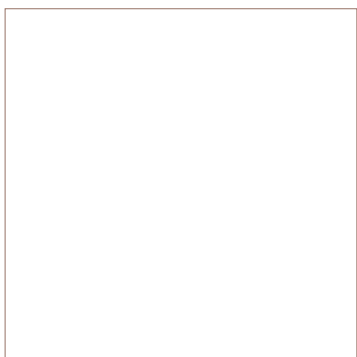

INFINITY

INN

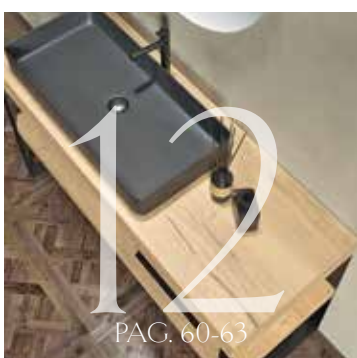
Con l'esperienza ventennale e dopo un'accurata ricerca stilistica e nelle materie prime noi della Disegno Bagno, chiamiamo Infinity questa collezione. Sia piccolo che grande, il bagno rappresenta comunque uno spazio per la calma e la serenità, dove ognuno può perdersi in infinite riflessioni, accarezzando con lo sguardo nuvole di schiuma o riflessi di marmo. Soluzioni versatili, modulabili e ricche di dotazioni e funzioni, che possono essere installate in qualunque tipo di spazio e ambiente. Infinity è essenziale e raffinata, merita di essere osservata da ogni angolazione, apprezzandone il design e le materie prime con le quali ha preso forma. Infinity è presunzione di nuovi orizzonti. Perfezione pura nelle forme, gioco modulabile di tanti elementi.

IN

INDICE

 1 PAG. 6-11		 2 PAG. 12-17	 3 PAG. 18-21
 4 PAG. 22-25	 5 PAG. 28-31	 6 PAG. 32-37	 7 PAG. 38-41
 8 PAG. 42-45		 9 PAG. 48-51	 10 PAG. 52-55
 11 PAG. 56-59	 12 PAG. 60-63	 13 PAG. 66-69	 14 PAG. 70-73
	 15 PAG. 76-79	 16 PAG. 82-85	 17 PAG. 88-91

COMPOSIZIONI

INFINITY



COMPOSIZIONE 1

La Composizione 1 si caratterizza per l'essenzialità; la base contrasta piacevolmente con un importante top in gres porcellanato, quasi a stabilirne l'equilibrio. Due ampi cassetti e un vano altrettanto profondo. Interessante il gioco di luce/riflessione della mensola inserita nello specchio.





IN1

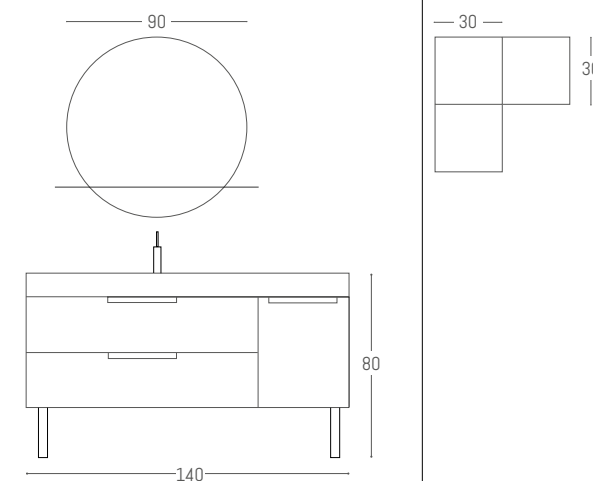

Composizione 1 > Sablè Afrormosia

- Art. F400
N°1 specchio led perimetrale sabbiato
Ø 90 cm. con mensola nera
- Art. S 1130
N°3 Vano a giorno con struttura metallica
nera e schienale L 30 x H 30 x P 18 cm.
- Art. GL-12
N°1 Top in gres porcellanato bianco
calacatta lucido L 140 x H 10 x P 51,5 cm.
- Art. S 1004
N°1 Base portalavabo due cassetti
L 100 x H 48 x P 51,5 cm.
- Art. S 1081
N°1 Base un'anta L 40 x H 48 x P 51,5 cm.
- Art. S 1180
N°2 Struttura metallica nera
L 4 x H 22 x P 48 cm.

INFINITY

IN1



IN2

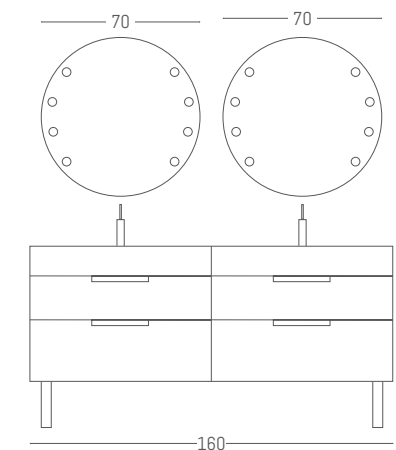

Composizione 2 > Riga Castoro Ottawa

Art. F 71
N°2 Specchio tondo con luci led frontali
cornice nera Ø 70 cm.

Art. GO - 12
N°1 Top in gres ardesia grigia opaca
L 160 x H 10 x P 51,5 cm.

Art. S 1002
N°2 Base portalavabo due cassette
L 80 x H 48 x P 51,5 cm.

Art. S 1180
N°2 Struttura metallica nera
L 4 x H 22 x P 48 cm.

IN2



COMPOSIZIONE 2

INFINITY

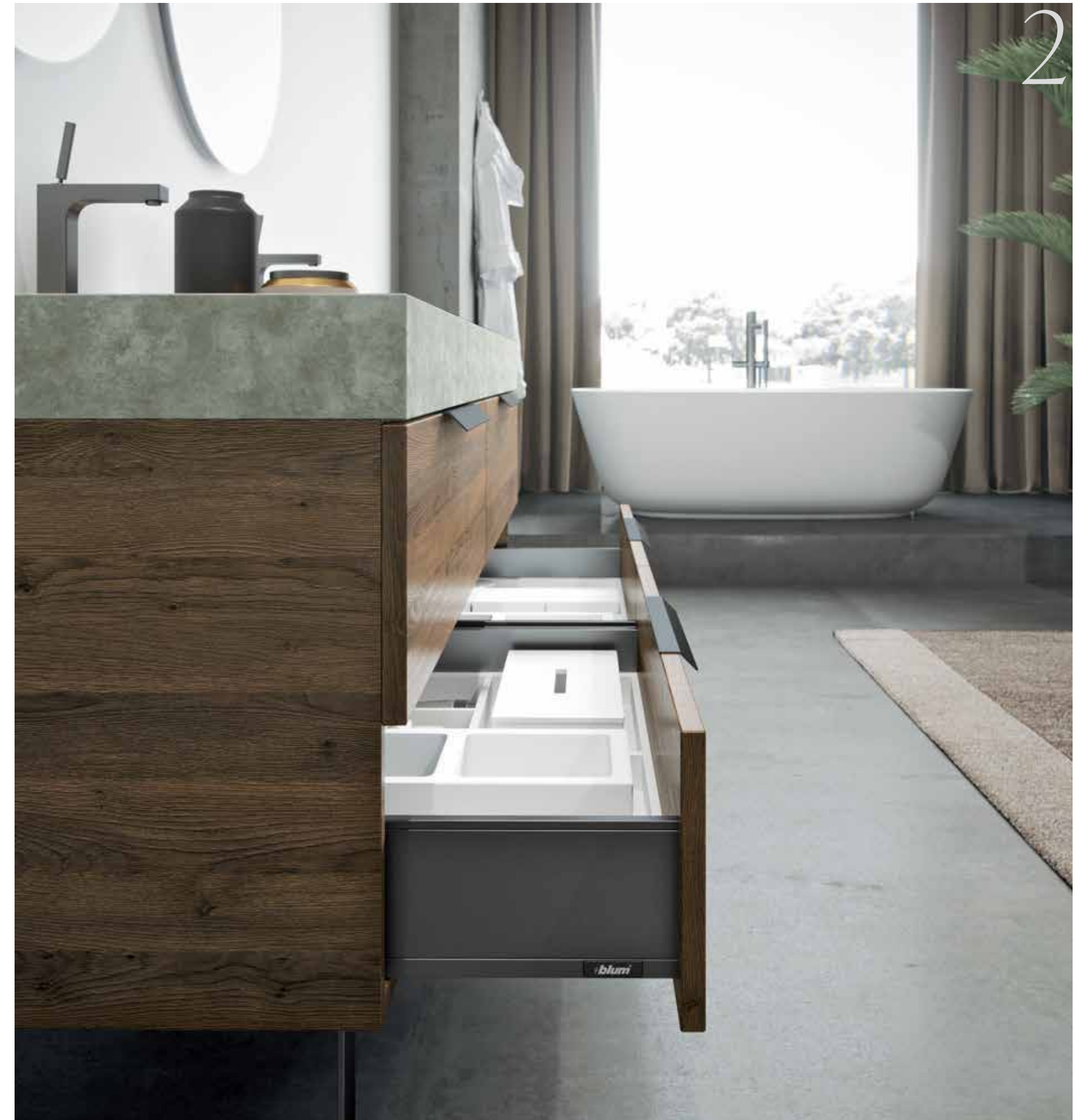

IN2

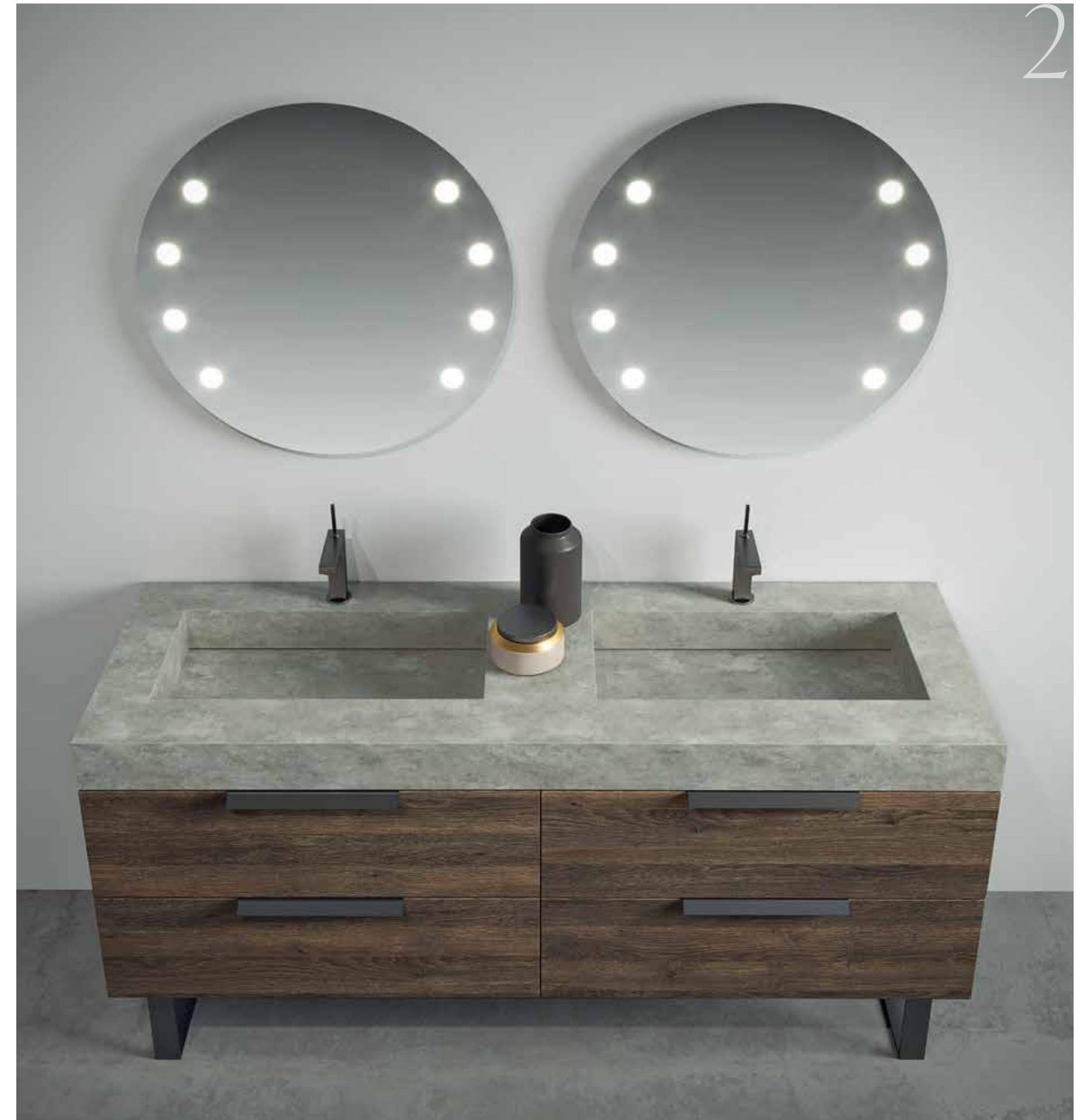

2



COMPOSIZIONE 3

Il bianco riflette e disperde tutte le lunghezze d'onda visibili della luce. Il nero assorbe tutti gli altri colori. Il bianco rappresenta il giorno, il nero la notte. Ecco il perfetto connubio per un mobile bagno semplicemente bello e realizzato con modernità.

INFINITY



IN3

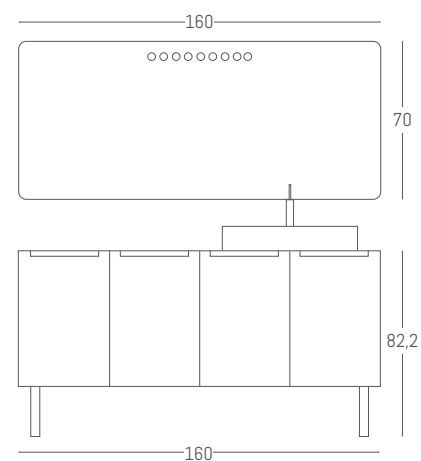

Composizione 3 > Bianco Opaco / Ardesia Nera

Art. F 68

N°1 Specchio con led perimetrale
luce frontale L 160 x H 70 cm.

Art. G0-2

N°1 Top in gres ardesia nera opaco
L 160 x H 1,2 x P 51,5 cm.

Art. O60

N°1 Lavabo in ceramica
lucida L 60 x H 11 x P 38 cm.

Art. S 1081

N°2 Base un'anta
L 40 x H 48 x P 51,5 cm.

Art. S 1042

N°1 Base portalavabo con due ante
L 80 x H 48 x P 51,5 cm.

N°2 Fianchi in gres ardesia nera opaca
L 48 x H 51,5 cm.

Art. S 1180

N°2 Struttura metallica nera
L 4 x H 22 x P 48 cm.



IN4



COMPOSIZIONE 4

Infinity numero 4 rappresenta razionalità.
Il gres nero marquina ne disegna la stabilità, abbinandosi perfettamente alla finitura del mobile.
Tutti gli elementi sembrano ruotare nello spazio. Modularità di una composizione veramente giocosa.

INFINITY



23 DISEGNO BAGNO

IN4

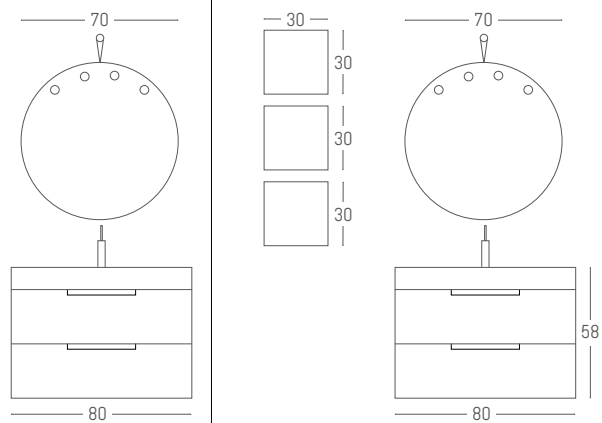

Composizione 4» Riga Bianco Efeso

Art. F100

N°1 Specchio con luci led frontali con cornice e gancio nero Ø 70 cm.

Art. GL-12

N°1 Top in gres nero marquinia lucido L 80 x H 10 x P 51,5 cm.

Art. S 1002

N°1 Base portalavabo con due cassetti L 80 x H 48 x P 51,5 cm.

Art. S 1130

N°3 Vano a giorno con struttura metallica nera e schienale L 30 x H 30 x P 18 cm.



4

IN



PARLIAMO
DI FINITURE,
SEMPLICEMENTE

INFINITE

FINITURE TOP GRES



ARDESIA BIANCA OPACO



ARDESIA GRIGIA OPACO



ARDESIA NERA OPACO



CALACATTA BIANCO LUCIDO



CALACATTA LUCIDO REX



EMPERADOR LUCIDO



GAUDÌ LUCIDO



GRIGIO AMANI LUCIDO



NERO MARQUINIA LUCIDO



NERO PORTORO LUCIDO

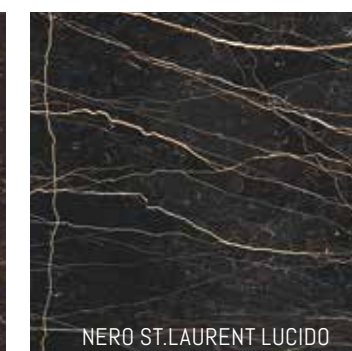

NERO ST. LAURENT LUCIDO



SPATOLATO IVORY OPACO



SPATOLATO SILVER OPACO



TRAVERTINO LUCIDO

I CAMPIONI RAFFIGURATI SONO A SCOPO PURAMENTE ILLUSTRATIVO



COMPOSIZIONE 5

Ancora l'eleganza del design è protagonista.
Infinity numero 5 si adegua allo spazio con giusti volumi pieni e vuoti e disposizione asimmetrica.
Lo specchio ovale con un'importante illuminazione a led, valorizza ulteriormente la composizione.

INFINITY





IN5

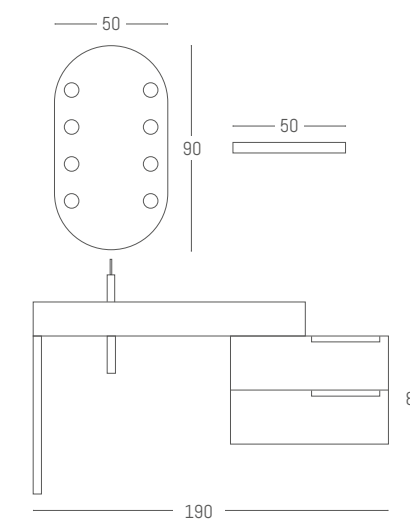

Composizione 5 - Sablè Cabreuva

- Art. F 80
N°1 Specchio ovale con luci led frontali e cornice nera L 50 x H 90 cm.
- Art. S 1160
N°1 Mensola nera in metallo L 50 x H 5 x P 14 cm.
- Art. ST 15CM
N°1 Top in stonelight sciolto L 120 x H 15 x P 51,5 cm.
- Art. S 1190
N°1 Struttura metallica nera con portasalviette L 4 x H 70 x P 48 cm.
- Art. S 1001
N°1 Base con due cassetti L 70 x H 48 x P 51,5 cm.
- N°1 Top di copertura L 70 x H 51,5 cm.

IN6



COMPOSIZIONE 6

INFINITY

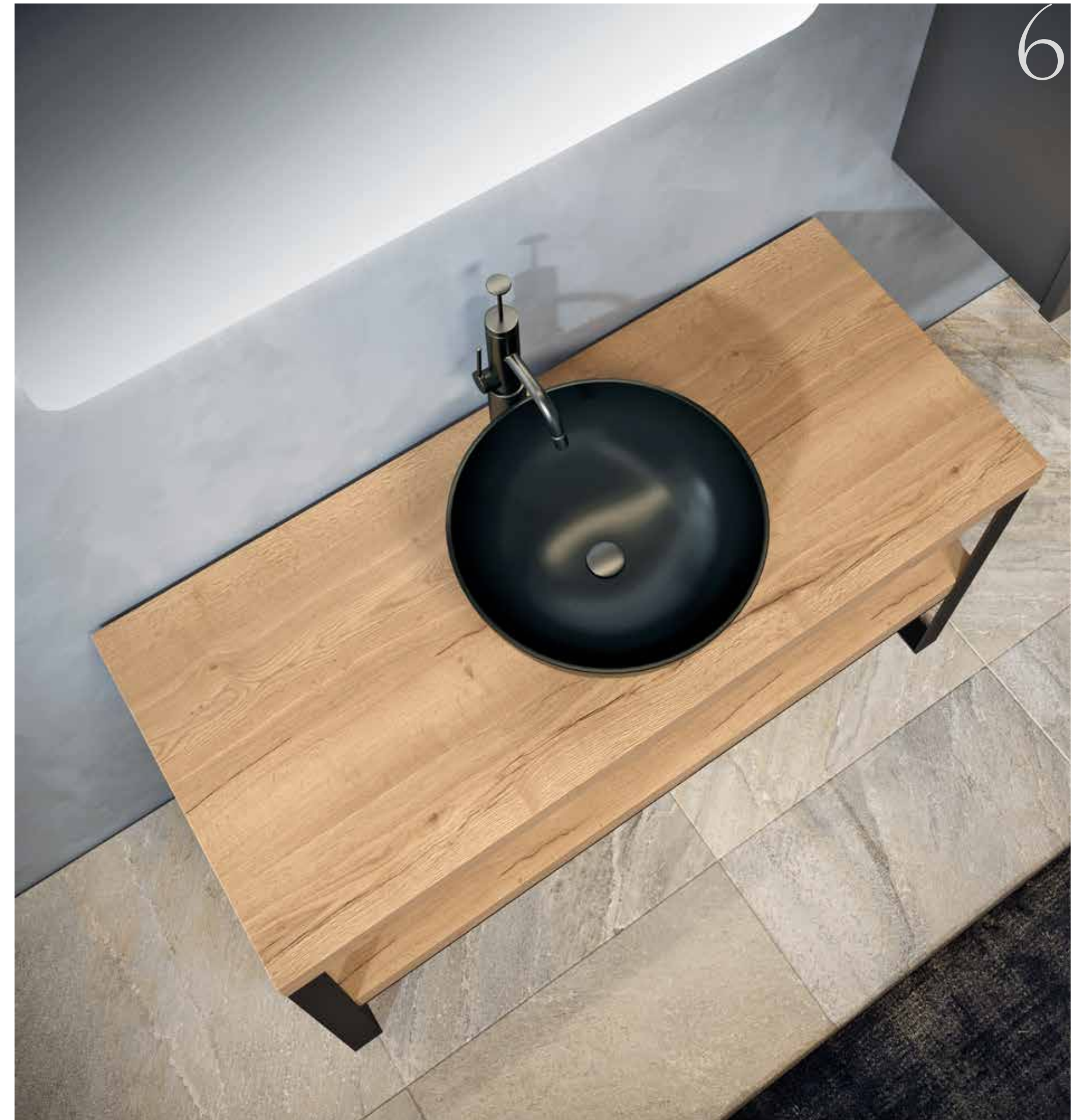

6

33 DISEGNO BAGNO

32 DISEGNO BAGNO



IN6

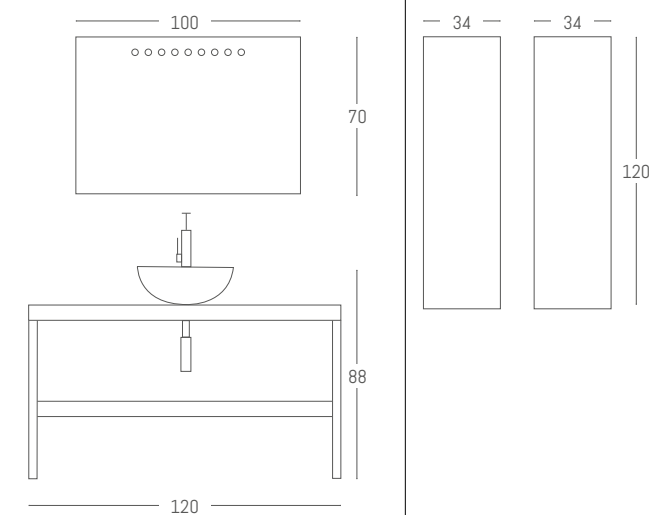

Composizione 6 > Massello/Rai 7024 Opaco

- Art. F 60
N°1 Specchio con led perimetrale
luce frontale L 100 x H 70 cm.
- Art. MDB-6
N°2 Top in massello
L 120 x H 6 x P 51,5 cm.
- Art. T 40
N°1 Lavabo in appoggio
ceramica nera Ø 40 x H 12 cm.
- Art. S 1200
N°2 Struttura metallica nera
predisposta per inserimento mensola
L 4 x H 70 x P 48 cm.
- Art. S 1140
N°2 Colonna 1 anta
L 34 x H 120 x P 36 cm.

IN6



6



COMPOSIZIONE 7

Infinity numero 7 è una vera e propria regina. Abbiamo scelto un grigio amani per il top in gres, un colore avvolgente per rifinirne la struttura, rassicurante e prezioso. Tanto spazio che si moltiplica grazie anche allo specchio ampio e rifinito da fasce sabbiate.

INFINITY





IN7

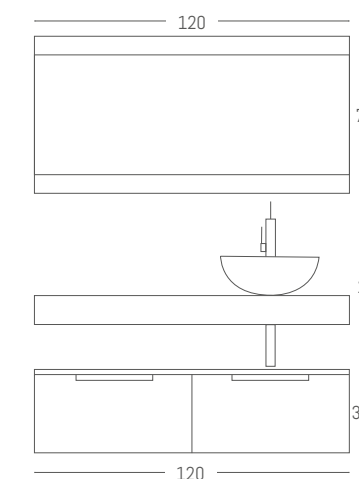

Composizione 7 > Bianco Lucido

Art. F94
N°1 Specchio con fasce sabbiate superiore e inferiore L 120 x H 70 cm.

Art. GL-20
N°1 Top in gres lucido grigio amani scatolato L 120 x H 10 x P 51,5 cm.

Art. 18
N°2 Staffe a scomparsa

Art. T-40
N°1 Lavabo in appoggio in ceramica Ø 40 x H 11 cm.

Art. GL-2
N°1 Top in gres amani lucido L 120 x H 1,2 x P 51,5 cm.

Art. S 1020
N°2 Base con un cassetto L 60 x H 32 x P 51,5 cm.



COMPOSIZIONE 8

INFINITY



IN8

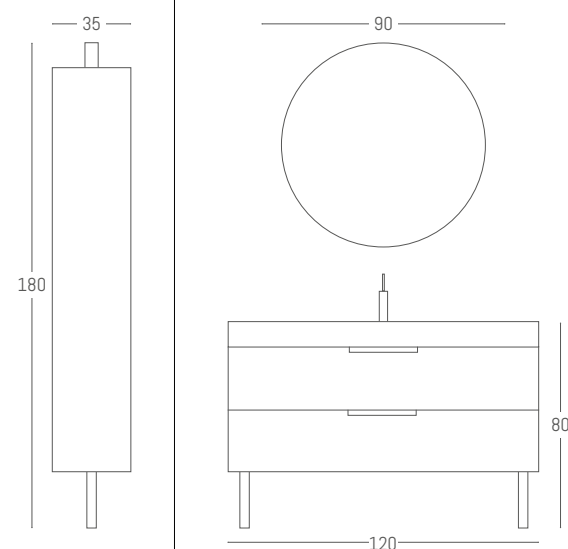

Composizione 8 - Riga Castoro Ottawa

Art. 90/L

N°1 Specchio a led perimetrale con sabbiatura Ø 90 cm.

Art. 60-12

N°1 Top in gres ardesia bianca opaca L 120 x H 10 x P 51,5 cm.

Art. S 1006

N°1 Base portalavabo due cassette L 120 x H 48 x P 51,5 cm.

Art. S 1180

N°2 Struttura metallica nera L 4 x H 22 x P 48 cm.

Art. S 1150

N°1 Colonna a giorno con struttura metallica ruotabile L 35 x H 180 x P 24 cm.



8

IN



LA NOSTRA STORIA
APPARTIENE ANCHE
ALL'ACQUA IN TUTTE
LE SUE PIEGHE CROMATICHE
INFINITE

FINITURE TOP HPL CUORE COLORE



BIANCO ALASKA



TRAVERTINO



GESSO

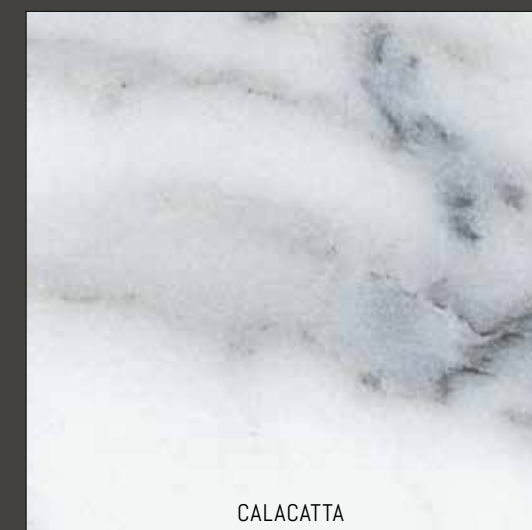

CALACATTA



SIENA



GRIGIO DI LONDRA

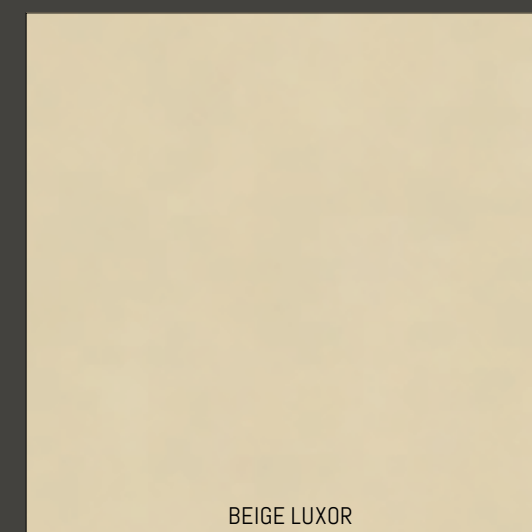

BEIGE LUXOR

I CAMPIONI RAFFIGURATI SONO A SCOPO PURAMENTE ILLUSTRATIVO

IN9



COMPOSIZIONE 9

Infinity numero 9 non accetta compromessi. Esce quasi dalla matita di un artista contemporaneo, che la colloca nello spazio come una bella signora vestita in toni primaverili. Sul top interamente in massello poggia un elegante lavabo ovale in ceramica spessa.

INFINITY



9



IN9

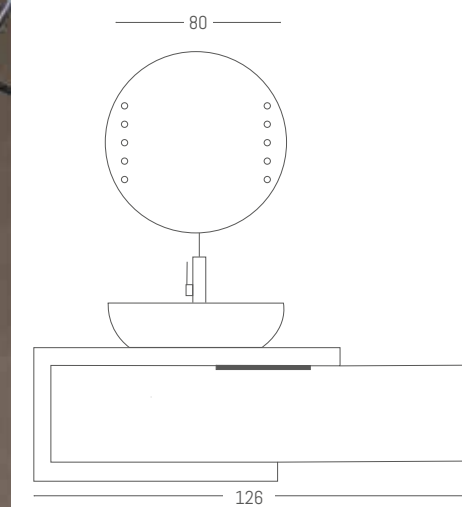

Composizione 9 - Bianco opaco

- Art. F300
- N°1 Specchio con luci led frontali Ø 80 cm.
- Art. MDB-6
- N°1 Struttura in massello
- L 60/90 x H 44 x P 55 x Sp 6 cm.
- Art. S88
- N°1 Lavabo in ceramica ovale
- L 88 x H 17/13 x P 44 cm.
- Art. S 1016
- N°1 Base con un cassetto
- L 120 x H 32 x P 55 cm.
- N°1 Top di copertura L 30 x P 55 cm.

IN10



COMPOSIZIONE 10

INFINITY

10



53 DISEGNO BAGNO

52 DISEGNO BAGNO

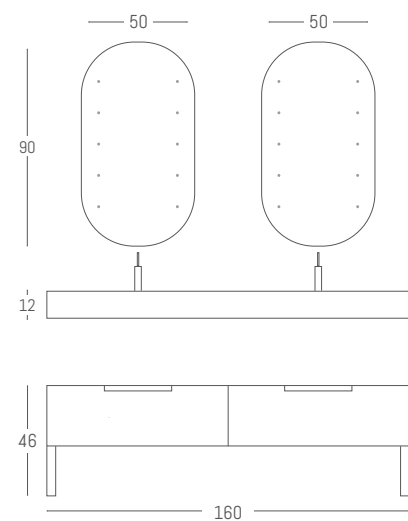

Composizione 10 > Ral 7044 Lucido

Art. F305
N°2 Specchio ovale
con luci led frontale L 50 x H 90 cm.

Art. GL-12
N°1 Top in gres gaudi lucido
L 160 x H 12 x P 51,5 cm.

Art. 18
N°2 Staffe a scomparsa

Art. S 1032
N°2 Base con un cassetto
L 80 x H 24 x P 51,5 cm

N°1 Top di copertura
L 160 x P 51,5 cm.

Art. S 1180
N°2 Struttura metallica nera
L 4 x H 22 x P 48 cm.





COMPOSIZIONE 11

Infinity 11 è una composizione estremamente versatile e innovativa, sia nelle linee che nell'abbinamento delle materie prime con cui è realizzata. Ottimiziamo lo spazio con una struttura metallica ruotabile porta oggetti e abbiniamo un lavabo circolare semplice ma elegante.

INFINITY





IN11

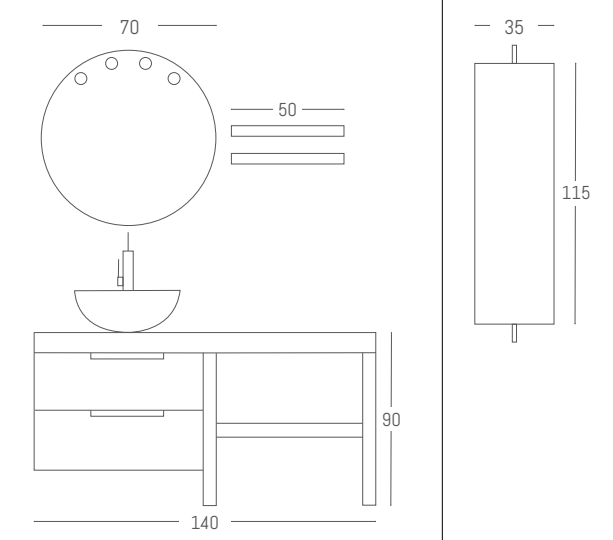

Composizione 11 > Riga rovere Arizona

- Art. 210
N°1 Specchio retroilluminato con luci led frontali Ø 70 cm.
- Art. S 1161
N°1 Mensola nera in metallo L 35 x H 5 x P 14 cm.
- Art. A 20
N°1 Top in HPL Lavagna sciolto L 140 x H 8 x P 51,5 cm.
- Art. T 40
N°1 Lavabo in appoggio in ceramica nera Ø 40 cm. x H 12 cm.
- Art. S 1001
N°1 Base portalavabo due cassette L 70 x H 48 x P 51,5 cm.
- Art. S 1200
N°2 Struttura metallica nera predisposta per inserimento mensola L 4 x H 70 x P 48 cm.
- Art. MP 52
N°1 Mensola scatolata L 70 x H 8 x P 50 cm.
- Art. S 1151
N°1 Colonna a giorno con struttura metallica ruotabile L 35 x H 115 x P 24 cm.



COMPOSIZIONE 12

INFINITY

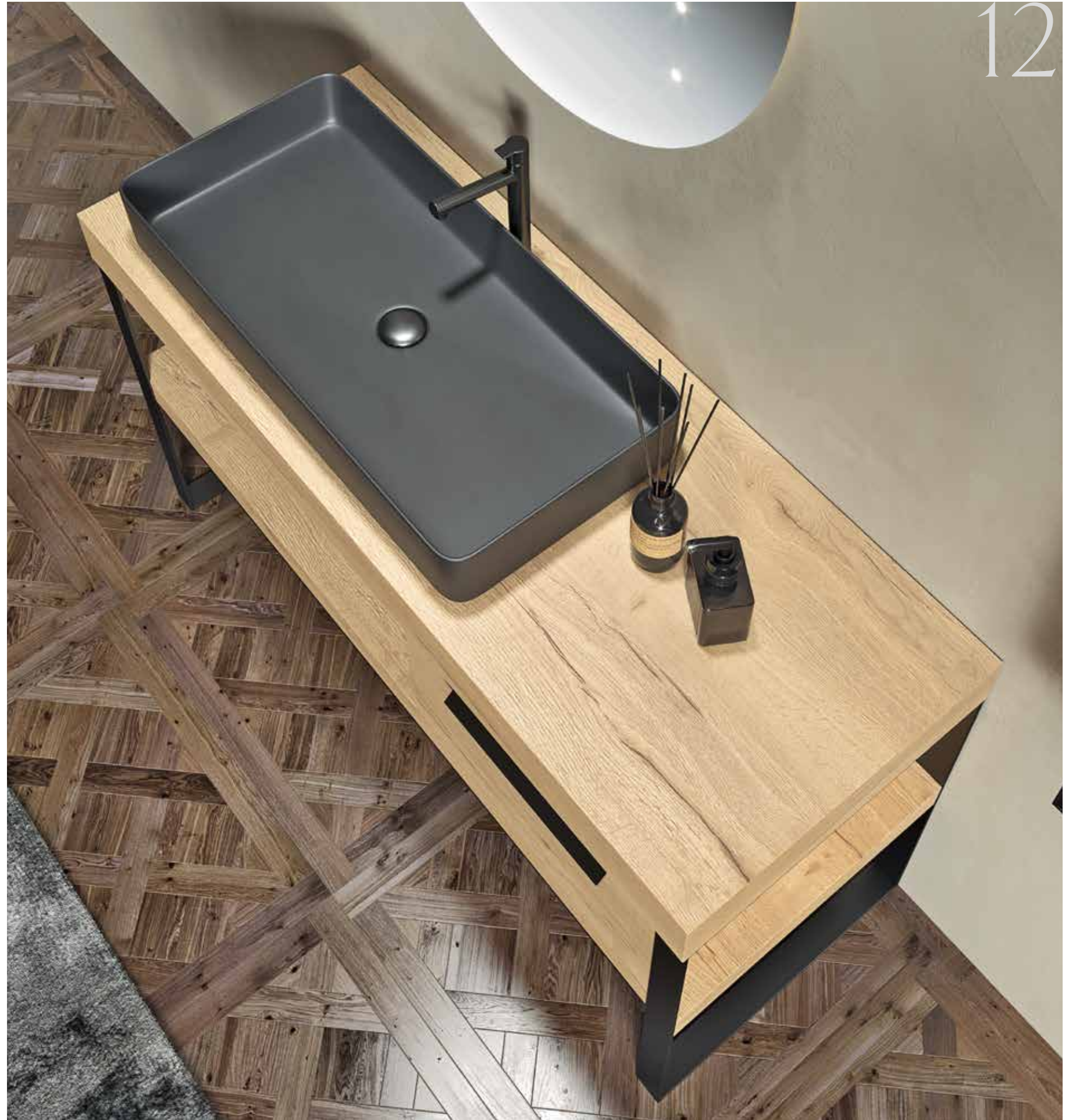



IN12

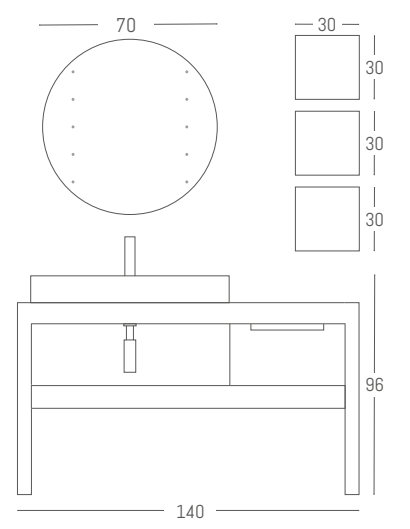

Composizione 12 > Sigaro toscano

- Art. F300
N°1 Specchio con luci led frontali
Ø 80 cm.
- Art. MP52
N°1 Tavola portalavabo scatolata
predisposta per lavabo in appoggio
L 140 x H 15 x P 51,5 cm.
- Art. O80
N°1 Lavabo in appoggio ceramica nero
L 80 x H 11 x P 38 cm.
- Art. S 1200
N°2 Struttura metallica nera
predisposto per inserimento mensola
L 4 x H 70 x P 48 cm.
- Art. S 1065
N°1 Base 1 cassetto
L 50 x H 40 x P 51,5 cm.
- Art. MP52
N°1 Tavola scatolata
L 140 x H 15 x P 51,5 cm.
- Art. S 1130
N°3 Vano a giorno con struttura
metallica nera e schienale
L 30 x H 30 x P 18 cm.

IN

PARLIAMO
DI FINITURE,
SEMPLICEMENTE

INFINITE



FINITURE HPL CUORE NERO



ALABASTRO GREY



ARGILLA



BARDIGLIO



CARBONE TAVOLATO



DARK

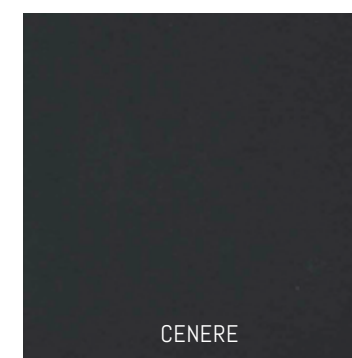

CENERE



GRIGIO CEMENTO

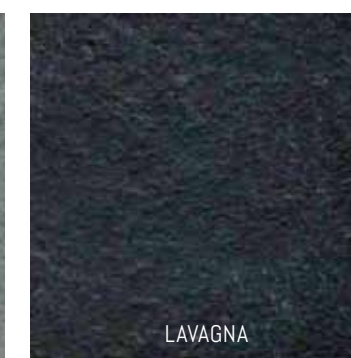

LAVAGNA

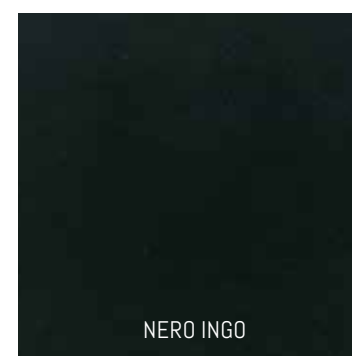

NERO INGO



NERO STREET



OSSIDO



OXUN



PERLATO



QUERCIA



ROVERE ANTICO



RUGGINE



TESTA DI MORO



VINTAGE FUMÈ

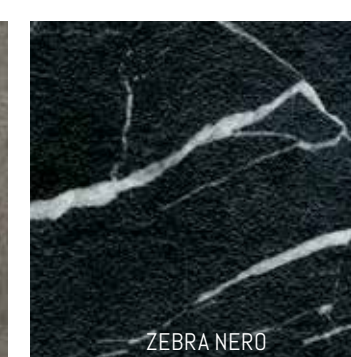

ZEBRA NERO

I CAMPIONI RAFFIGURATI SONO A SCOPO PURAMENTE ILLUSTRATIVO

IN13



COMPOSIZIONE 13

La numero 13 è la più fortunata. Due specchi con doppia sabbatura e retro illuminati, due bellissimi lavabi in ceramica dalla forma estremamente moderna e la finitura di un mobile versatile sia in ambienti moderni che più sofisticati.

INFINITY



DISEGNO BAGNO

DISEGNO BAGNO



IN13

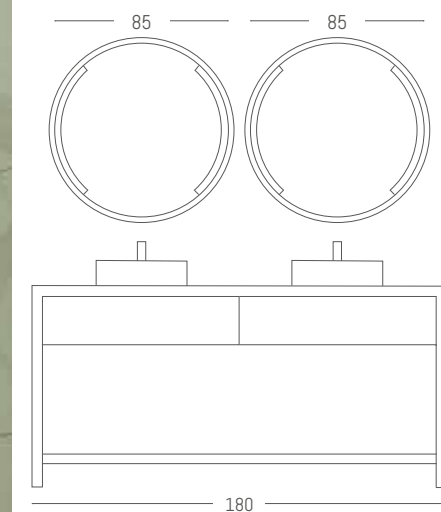

Composizione 13 > Massello rovere nodato

- Art. F 85
N°2 Specchio retroilluminato
con doppia sabbatura Ø 85 cm.
- Art. S 1350
N°1 Base portalavabo con due cassette
in massello L 180 x H 70 x P 51,5 cm.
- Art. 060
N°2 Lavabo in appoggio in ceramica
L 60 x H 11 x P 38 cm.

IN 14



COMPOSIZIONE 14

INFINITY



IN 14

DISEGNO BAGNO



IN14

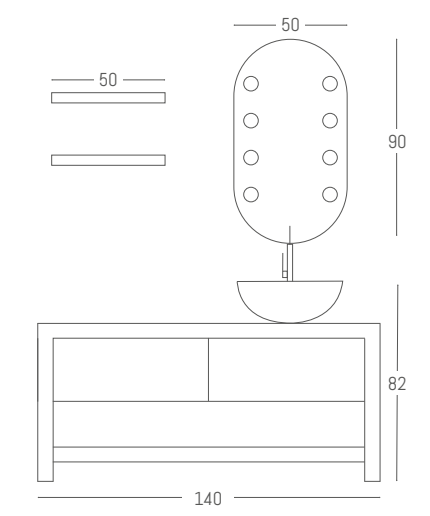

Composizione 14 › Massello noce nazionale

- Art. F 305
N°1 Specchio ovale con luci led frontale
cornice bianca L 50 x H 90 cm.
- Art. S 1420
N°2 Mensole in massello
L 50 x H 6 x P 30 cm.
- Art. S 1310
N°1 Base portalavabo con due cassetti
in massello L 140 x H 70 x P 51,5 cm.
- Art. T 40
N°1 Lavabo in appoggio ceramica
Ø 40 x H 12 cm.



FINITURE MOBILI



RIGA CASTORO OTTAWA



SABLÈ CABREUVA

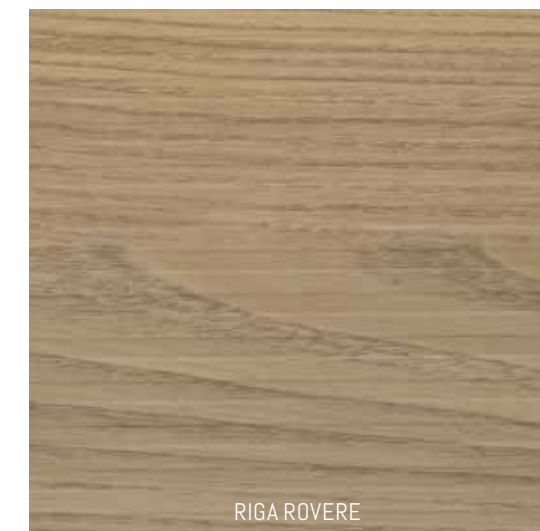

RIGA ROVERE



SABLÈ AFRORMOSIA



RIGA BIANCO EFESO

I CAMPIONI RAFFIGURATI SONO A SCOPO PURAMENTE ILLUSTRATIVO



COMPOSIZIONE 15

Infinity numero 15 è caratterizzata da una tavola in massello scortecciato, una scelta coraggiosa ed entusiasmante. Il vano porta oggetti si colloca immediatamente sotto, ampio e spazioso. Scegliamo un lavabo altrettanto importante e volutamente nero, un ulteriore tocco di modernità.

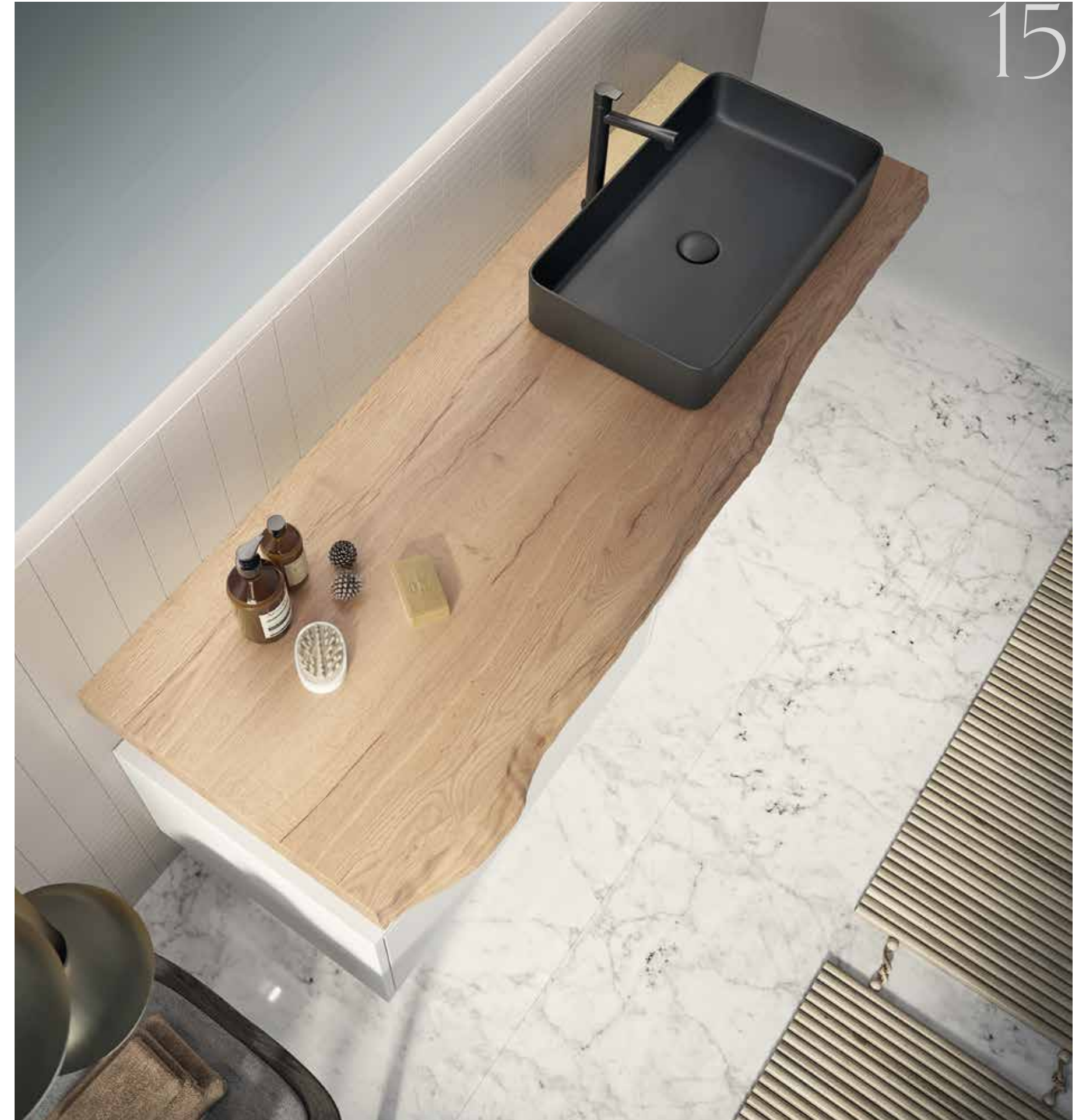

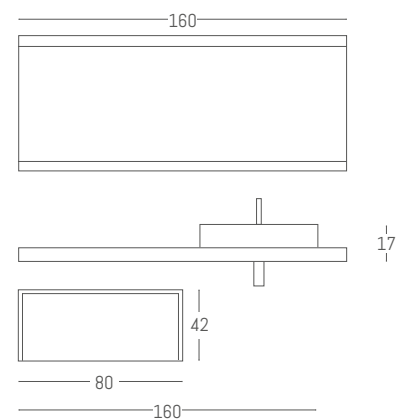

Composizione 15 > Massello scortecciato bianco opaco

Art. F 98

N°1 Specchio con fasce sabbiate superiore e inferiore L 160 x H 70 cm.

Art. MBS6

N°1 Tavola in massello scortecciato L 160 x H 6 x P 51,5 cm.

Art. 18

N°3 Staffe a scomparsa

Art. S 1012

N°1 Base con un cassetto L 80 x H 40 x P 51,5 cm.

N°1 Top di copertura L 80 x P 51,5 cm.

Art. 060

N°1 Lavabo in appoggio nero rettangolare L 60 x H 11 x P 38 cm.



IN



IN 16



COMPOSIZIONE 16

Infinity numero 16 si compone di 5 elementi, l'uno dipende dall'altro in un equilibrio di forme essenziali come lo sono le materie prime e le finiture.

INFINITY



16

DISEGNO BAGNO



IN16

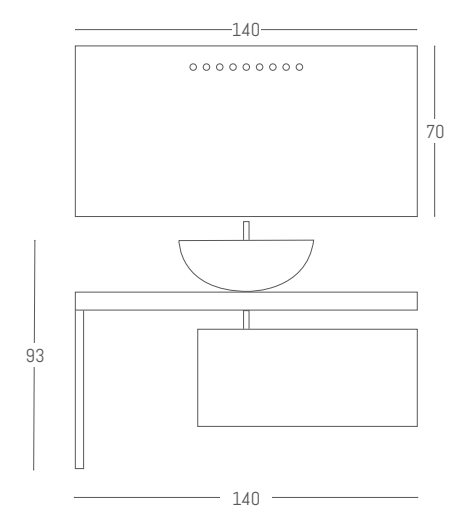

Composizione 16 - Massello rovere scortecciato nodato/nero opaco

- Art. F 66
N°1 Specchio con led perimetrale luce frontale L 140 x H 70 cm.
- Art. MBS 6
N°1 Tavola in massello rovere nodato scortecciato L 140 x H 6 x P 51,5 cm.
- Art. S 1190
N°1 Struttura metallica nera con portasalviette L 4 x H 70 x P 48 cm.
- Art. 18
N°1 Staffe a scomparsa
- Art. S 1013
N°1 Base con un cassetto L 90 x H 40 x P 51,5 cm.
- N°1 Top di copertura cm. 90 x 51,5 cm.
- Art. S 88
N°1 Lavabo in ceramica ovale L 88 x H 17/13 x P 44 cm.

IN



IN17



COMPOSIZIONE 17

INFINITY



17

DISEGNO BAGNO

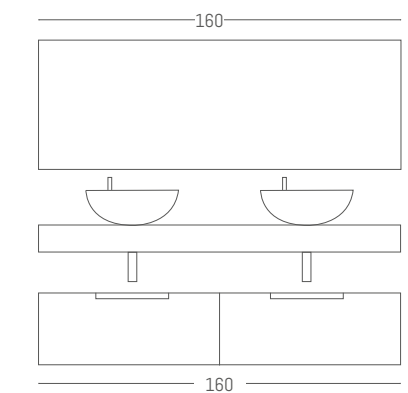

Composizione 17 > Massello scatoiato rovere nodato/nero opaco

Art. F 98
N°1 Specchio FL. a led perimetrale
L 160 x H 70 cm.

Art. MSCAT 6
N°1 Mensola portavavabo
scatoiato
L 160 x H 10 x P 51,5 cm.

Art. 18
N°3 Staffe a scomparsa

Art. T 40
N°2 Lavabo in appoggio ceramica
Ø 40 x H 12 cm.

Art. S 1022
N°2 Base con un cassetto
L 80 x H 32 x P 51,5 cm.

N°1 Top di copertura
L 160 x H 1,9 x P 51,5 cm.

IN

INFINE

Infinity, abbiamo giocato con questa parola.
Ma reali e bellissime sono le 17 composizioni che la compongono.
L'obiettivo era quello di strutturare una collezione che potesse durare nel tempo, versatile, creativa
per valorizzare il vostro spazio confidenziale.

IN



IN



DESIGN DISEGNO BAGNO
PROGETTO GRAFICO E STAMPA
EUROSTAMPA SRL PONTEDERA

INFINITY

IN

INFINITY

